

REFPLUS

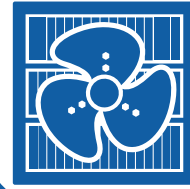

IDEAL FOR COOLERS ABOVE +34°F

- Low air, blow-through units
- Capacity from 7,000 to 42,000 BTU/HR./10°F TD

LVA

FOR COOLERS ABOVE +26°F

- Low air, blow-through units
- Capacity from 7,000 to 42,000 BTU/HR./10°F TD

LVE, LVG & LVH

COMMERCIAL WALK-IN COOLERS
LOW VELOCITY



Certified ISO-9001

DEFROST SPECIFICATIONS

APPLICATIONS: COOLERS ABOVE +34°F

LVA - AIR DEFROST SPECIFICATIONS

Model	CFM	CAPACITY BTUH				FAN MOTOR FLA					Fuse Size	R-404A, R-507 Operating Charge (lb.)
		8°F TD	10°F TD	12°F TD	15°F TD	1 Phase		3 Phase ^m				
						120 V.	240 V.	240 V.	480 V.	600 V.		
LVA 0700	900	5600	7000	8400	10500	1.48	0.72	0.62	NA	NA	15	2.7
LVA 0800	1000	6400	8000	9600	12000	1.48	0.72	0.62	NA	NA	15	3.6
LVA 0900	1100	7200	9000	10800	13500	1.48	0.72	0.62	NA	NA	15	3.9
LVA 1200	1400	9600	12000	14400	18000	3.20	1.60	1.39	NA	NA	15	5.3
LVA 1500	1900	12000	15000	18000	22500	2.00	1.00	0.87	NA	NA	15	5.2
LVA 1900	2060	15200	19000	22800	28500	2.00	1.00	0.87	NA	NA	15	6.9
LVA 2400	2600	19200	24000	28800	36000	8.60	3.20	2.77	1.10	0.70	15	8.6
LVA 2700	3200	21600	27000	32400	40500	8.60	3.20	2.77	1.10	0.70	15	8.1
LVA 3000	3000	24000	30000	36000	45000	8.60	3.20	2.77	1.10	0.70	15	10.8
LVA 3600	3860	28800	36000	43200	54000	8.60	3.20	2.77	1.10	0.70	15	12.9
LVA 4200	4900	33600	42000	50400	63000	8.60	3.20	2.77	1.10	0.70	15	15.5

APPLICATIONS: COOLERS FROM +26°F TO +34°F

LVE - ELECTRIC DEFROST SPECIFICATIONS

Model	CFM	CAPACITY BTUH				FAN MOTOR FLA				DEFROST HEATER ELECTRICAL DATA												R-404A, R-507 Operating Charge (lb.)			
		8°F TD	10°F TD	12°F TD	15°F TD	1 Phase		3 Phase ^m		240/1/60		208/3/60		240/3/60		480/3/60		600/3/60							
						240 V.	240 V.	480 V.	600 V.	kW	FLA	Fuse	kW	FLA	Fuse	kW	FLA	Fuse	kW	FLA	Fuse		kW	FLA	Fuse
LVE 0700	890	5600	7000	8400	10500	0.72	0.62	NA	NA	1.9	8.0	15	1.9	5.3	15	2.6	6.2	15	1.6	1.9	15	1.9	1.8	15	5.1
LVE 0800	980	6400	8000	9600	12000	0.72	0.62	NA	NA	1.9	8.0	15	1.9	5.3	15	2.6	6.2	15	1.6	1.9	15	1.9	1.8	15	6.7
LVE 0900	1060	7200	9000	10800	13500	0.72	0.62	NA	NA	2.9	12.0	15	2.9	8.0	15	3.8	9.2	15	2.5	3.0	15	2.9	2.8	15	7.4
LVE 1200	1300	9600	12000	14400	18000	1.60	1.39	NA	NA	2.9	12.0	15	2.9	8.0	15	3.8	9.2	15	2.5	3.0	15	2.9	2.8	15	9.9
LVE 1500	1860	12000	15000	18000	22500	1.00	0.87	NA	NA	3.8	16.0	20	3.8	10.7	15	5.1	12.0	20	3.3	4.0	15	3.8	3.7	15	9.8
LVE 1900	2000	15200	19000	22800	28500	1.00	0.87	NA	NA	3.8	16.0	20	3.8	10.7	15	5.1	12.0	20	3.3	4.0	15	3.8	3.7	15	13.1
LVE 2400	2550	19200	24000	28800	36000	3.20	2.77	1.10	0.70	3.8	16.0	20	3.8	10.7	15	5.1	12.0	20	3.3	4.0	15	3.8	3.7	15	16.4
LVE 2700	2900	21600	27000	32400	40500	3.20	2.77	1.10	0.70	4.8	20.0	25	4.8	13.3	20	6.4	15.0	20	4.1	4.9	15	4.8	4.6	15	15.3
LVE 3000	3340	24000	30000	36000	45000	3.20	2.77	1.10	0.70	4.8	20.0	25	4.8	13.3	20	6.4	15.0	20	4.1	4.9	15	4.8	4.6	15	20.4
LVE 3600	3800	28800	36000	43200	54000	3.20	2.77	1.10	0.70	4.8	20.0	25	4.8	13.3	20	6.4	15.0	20	4.1	4.9	15	4.8	4.6	15	24.5
LVE 4200	4820	33600	42000	50400	63000	3.20	2.77	1.10	0.70	5.8	24.0	30	5.8	16.0	20	7.7	19.0	25	4.9	5.9	15	5.8	5.5	15	29.4

APPLICATIONS: COOLERS FROM +26°F TO +34°F

LVG, LVH - GAS DEFROST SPECIFICATIONS

Model	CFM	CAPACITY BTUH				FAN MOTOR FLA				DEFROST HEATER ELECTRICAL DATA						R-404A, R-507 Operating Charge (lb.)
		8°F TD	10°F TD	12°F TD	15°F TD	1 Phase		3 Phase ^m		120/1/60		240/1/60				
						120 V.	240 V.	kW	FLA	Fuse	kW	FLA	Fuse	kW	FLA	
LV(G)(H) 0700	900	5600	7000	8400	10500	1.48	0.72	0.64	5.3	15	0.64	2.7	15	2.7		
LV(G)(H) 0800	1000	6400	8000	9600	12000	1.48	0.72	0.64	5.3	15	0.64	2.7	15	3.6		
LV(G)(H) 0900	1100	7200	9000	10800	13500	1.48	0.72	0.96	8.0	15	0.96	4.0	15	3.9		
LV(G)(H) 1200	1400	9600	12000	14400	18000	3.20	1.60	0.96	8.0	15	0.96	4.0	15	5.3		
LV(G)(H) 1500	1900	12000	15000	18000	22500	2.00	1.00	1.28	10.7	15	1.28	5.3	15	5.2		
LV(G)(H) 1900	2060	15200	19000	22800	28500	2.00	1.00	1.28	10.7	15	1.28	5.3	15	6.9		
LV(G)(H) 2400	2600	19200	24000	28800	36000	8.60	3.20	1.28	10.7	15	1.28	5.3	15	8.6		
LV(G)(H) 2700	3200	21600	27000	32400	40500	8.60	3.20	1.60	13.3	20	1.60	6.7	15	8.1		
LV(G)(H) 3000	3000	24000	30000	36000	45000	8.60	3.20	1.60	13.3	20	1.60	6.7	15	10.8		
LV(G)(H) 3600	3860	28800	36000	43200	54000	8.60	3.20	1.60	13.3	20	1.60	6.7	15	12.9		
LV(G)(H) 4200	4900	33600	42000	50400	63000	8.60	3.20	1.92	16.0	20	1.92	8.0	15	15.5		

NOTES:

- (1) Single phase motors wired for three-phase power supply.
- (2) For 4 FPI, multiply capacity by 0.85.
- (3) Operating charge is based on 30% liquid and 70% vapor at 25°F suction.
- (4) R-134a refrigerant charge, multiply R-404A by 1.09.
- (5) Fan motor heat is not included in rating, add 396 BTUH (0700 to 0900), 683 BTUH (1200 to 1900) and 2125 BTUH (2400 to 4200).
- (6) Use suffix 1 for 120/1/60, 2 for 240/1/60, 5 for 208-240/3/60, 9 for 480/3/60 and 8 for 600/3/60.

GAS DEFROST PIPING DIAGRAM

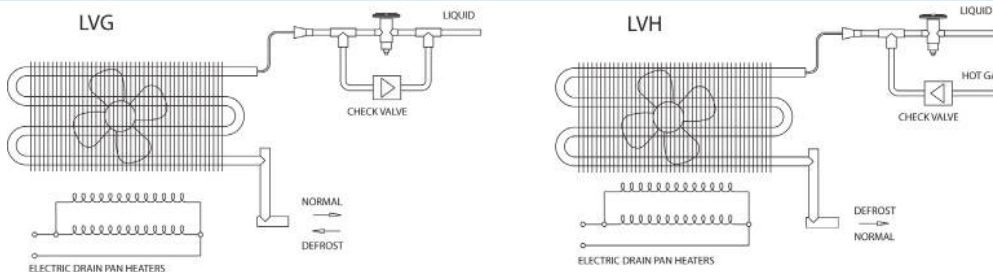

TECHNICAL DATA

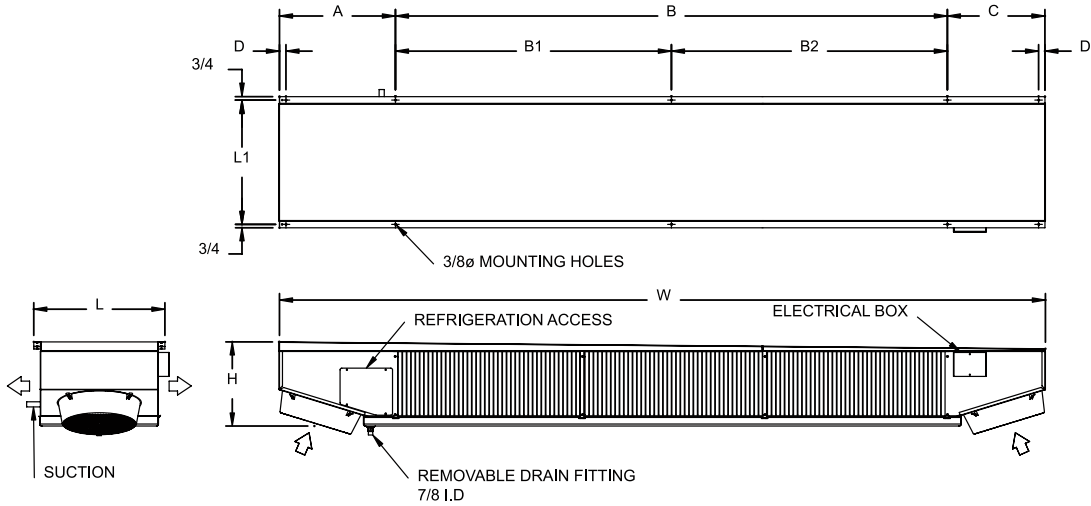

LV SERIES

Model	Shipping Weight (lb.)			Unit Dimensions (Inches)										Connection (Inches)		
	LVA	LVE	LVG(H)	W	H	L	L1	A	B	B1	B2	C	D	Liquid	Suction	LVH Hot Gas
LVA (E)(G)(H) 0700	110	120	114	78	12 5/8	22 3/4	21 1/4	20 1/2	41	-	-	16 1/2	-	1/2	5/8	1/2
LVA (E)(G)(H) 0800	118	130	122	78	12 5/8	22 3/4	21 1/4	20 1/2	41	-	-	16 1/2	-	1/2	5/8	1/2
LVA (E)(G)(H) 0900	141	154	145	98	13	22 3/4	21 1/4	20 1/2	61	-	-	16 1/2	-	1/2	5/8	1/2
LVA (E)(G)(H) 1200	159	177	165	98	13	22 3/4	21 1/4	20 1/2	61	-	-	16 1/2	-	1/2	7/8	1/2
LVA (E)(G)(H) 1500	179	197	185	118	13	22 3/4	21 1/4	20 1/2	-	41	40	16 1/2	-	1/2	7/8	1/2
LVA (E)(G)(H) 1900	195	217	201	118	13	22 3/4	21 1/4	20 1/2	-	41	40	16 1/2	-	1/2	7/8	1/2
LVA (E)(G)(H) 2400	254	282	262	128	15 7/8	22 3/4	21 1/4	20 1/2	-	40	41	21 1/2	1 1/2	1/2	7/8	1/2
LVA (E)(G)(H) 2700	298	325	306	148	15 7/8	28 3/4	27 1/4	20 1/2	-	61	40	21 1/2	1 1/2	1/2	7/8	1/2
LVA (E)(G)(H) 3000	323	356	331	148	15 7/8	28 3/4	27 1/4	20 1/2	-	61	40	21 1/2	1 1/2	1/2	7/8	1/2
LVA (E)(G)(H) 3600	352	390	360	148	18 3/8	28 3/4	27 1/4	20 1/2	-	61	40	21 1/2	1 1/2	7/8	1 1/8	5/8
LVA (E)(G)(H) 4200	396	440	404	168	18 3/8	28 3/4	27 1/4	20 1/2	-	60 1/2	60 1/2	21 1/2	1 1/2	7/8	1 1/8	5/8

WIRING DIAGRAMS

LVG, LVH

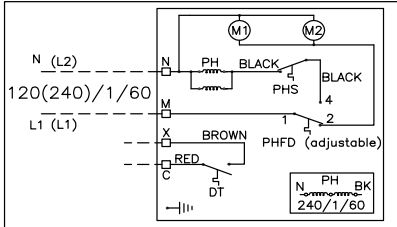

LVA

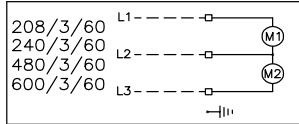

LVA

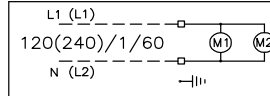

- DH: DEFROST HEATER
- DT: DEFROST TIMER
- DTFD: DEFROST TERMINATION FAN DELAY
- HS: HEATER SAFETY
- LS: LIQUID LINE SOLENOID
- M1: FAN MOTOR INTERNALLY PROTECTED
- RT: ROOM THERMOSTAT
- TM: TIMER MOTOR
- WTH: WALL THERMOSTAT
- 1C: EVAPORATOR HEATERS CONTACTOR
- 1F: EVAPORATOR FAN CONTACTOR
- 1T: EVAPORATOR HEATERS CONTACTOR
- : TERMINAL BLOCK
- : BY OTHERS

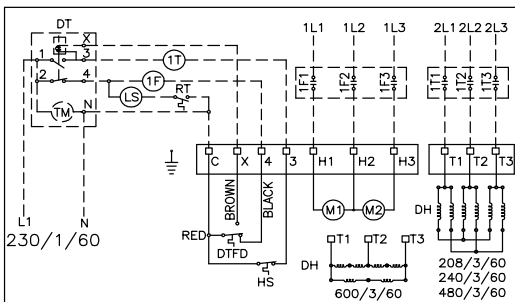

LVE - PILOT DUTY

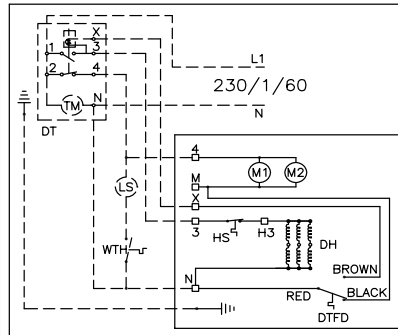

LVE - LINE DUTY

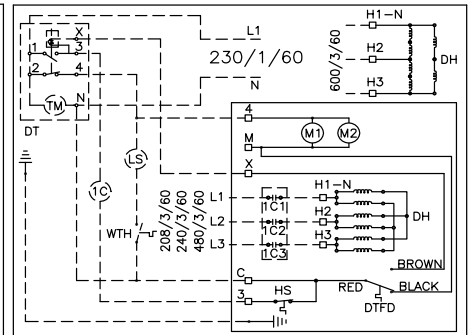

LVE - LINE AND PILOT DUTY

SPECIFICATIONS

APPLICATIONS

LVA Models are for coolers +34°F and above.

LVE, LVG and LVH Models are for coolers +26°F and above

SPECIFICATIONS

Low velocity LV series are a dual coil construction for an equal air distribution on both sides of the unit. The fans draw air upward through the fan guards and discharge it through each evaporator coils.

COILS are manufactured with seamless deoxidized heavy wall smooth copper tubes and aluminium plate fins. For a maximum heat transfer, the tubes are mechanically expanded into self-spaced plate fins with full collar for a permanent bond. Connections and bends are brazed with high temperature brazing alloy. Coils are factory leak tested at 600 psig and purged with a -40°F dew point dry air. Coils are circuited for HFC refrigerant.

CASING material for standard LV series is heavy gauge white painted aluminium. All units come with stainless steel or plated hardware for a lightweight assembly. For avoiding the formation of condensation and sweating, LV series are provided with triple drain pan.

DRAIN

All units are provided with a removable 7/8" I.D. copper drain fitting for ease off installation and cleaning.

MOTOR

Heavy-duty totally enclosed air over (open construction on LV 1200 and for 120/1/60 motor on LV 2400 to 4200) fan motors are provided for long life and dependable service. They are permanently lubricated and thermally protected. They are available for 120/1/60, 208-240/1/60 or 208-240/3/60 supply.

Models LV 2400 and larger are also available for 480/3/60 or 600/3/60 supply.

FAN BLADES are aluminum made and stamped to an aluminium hub for lightweight (LV 1200 to 4200); stamped aluminum hubless fan blades (LV 0700 to 900). Fan assemblies are statically and dynamically balanced for smooth and vibration free operation.

FAN GUARDS are injection-molded polymers for consistency of dimensions and full protection of moving parts.

ALL units are assembled with corrosion free material and components.

LVE models are provided with a sealed, non-adjustable, fan delay / defrost termination thermostat and a heater safety thermostat. All units feature incoloy low watt density tubular heaters. They are imbedded within the coil for positive defrost and high-energy efficiency. This reduces heat gain in coolers and freezers. All units use six heaters for 208-240/1/60 or 208-240/3/60 or 480/3/60 or 600/3/60 supply.

LVG and LVH models are provided with an adjustable fan delay thermostat and non-adjustable defrost termination thermostat, heater safety thermostat and electric drain pan heaters. Use LVG models for reverse cycle defrost or LVH models for three pipe-defrost.

ALL models are provided with terminal block for easier field wiring. Terminals are clearly identified to match wiring diagram supplied with the unit.

ALL walk-in unit coolers are of modular design using a minimum of different parts to simplify replacement and to reduce inventory.



Certified ISO-9001